

TUTTI I PROFILI SONO REALIZZATI IN ALLUMINIO VERNICIATO A POLVERI POLIESTERE LEGA 6060 STATO T5 o T6 CON UNO SPESSORE VARIABILE TRA 1,5 - 2 mm. (scala 1:2)

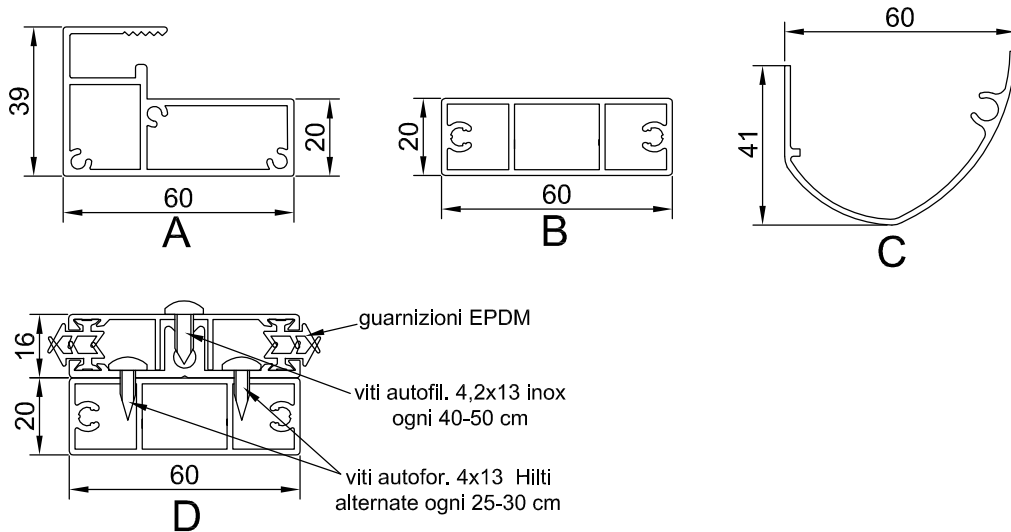

CODICE	S cm	L max cm	Area mq	H cm	h cm
CL060	60	280	1,68	23,6	16,8
CL070	70	270	1,89	26,4	19,6
CL080	80	260	2,08	29,2	22,4
CL090	90	250	2,25	32	36
CL100	100	240	2,4	34,8	36
CL110	110	218	2,39	37,6	36
CL120	120	200	2,4	40,4	45
CL130	130	184	2,39	43,2	45
CL140	140	170	2,38	46	52
CL150	150	160	2,4	48,8	52

CODICE	DATA	PROFILI ALLUMINIO
CLxxx	24/04/12	ESTRUSO ALLUMINIO 6060 STATO T5 o T6
	SCALA	LASTRE DI COPERTURA
	---	POLICARBONATO COMPATTO SPESS. 4 mm.

DESCRIZIONE	GUARNIZIONI EPDM
PENSILINA LUNA S = 60-150	DISEGNATO
	APPROVATO

REV.	DESCRIZIONE REVISIONE	DATA
06	----	----
05	----	----
04	----	----
03	----	----
02	----	----
01	----	----
00	PRIMA EMISSIONE DEL DISEGNO	24/04/12



