

TUTTI I PROFILI SONO REALIZZATI IN ALLUMINIO VERNICIATO A POLVERI POLIESTERE LEGA 6060 STATO T5 o T6 CON UNO SPESSORE VARIABILE TRA 1,5 - 2 mm. OVE NON DIVERSAMENTE INDICATO (scala 1:2)

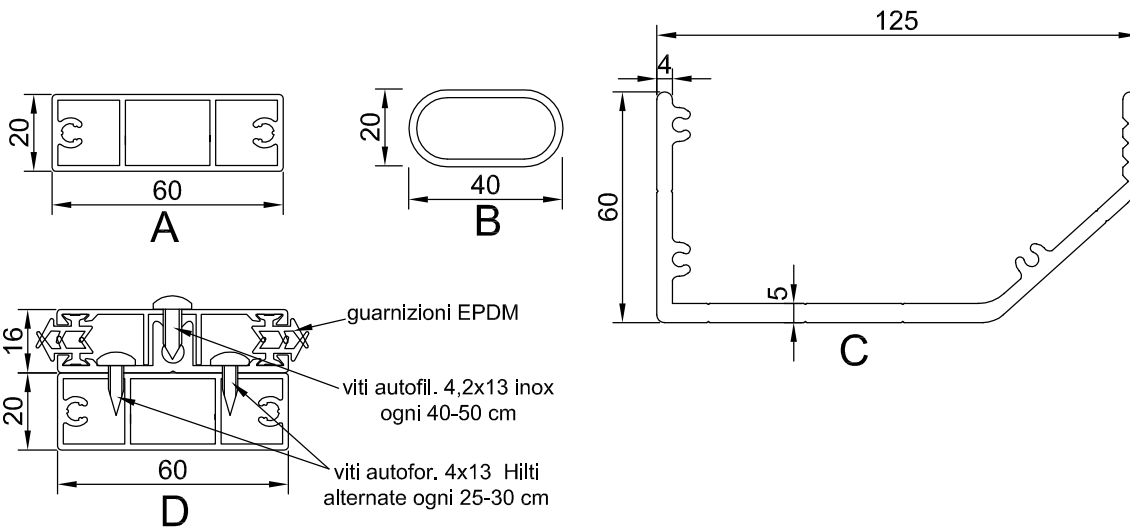

CODICE	S cm	L max cm	Area mq	H cm	h cm
TP060	60	250	1,50	min. 1/5 L max 1/2 L	21
TP070	70		1,75		25
TP080	80		2,00		29
TP090	90		2,25		33
TP100	100		2,50		37
TP110	110		2,75		40
TP120	120		3,00		44
TP130	130		3,25		47
TP140	140		3,50		51
TP150	150		3,75		55

CODICE **TPxxx** DATA 24/04/12 PROFILI ALLUMINIO ESTRUSO ALLUMINIO 6060 STATO T5 o T6
 SCALA --- LASTRE DI COPERTURA POLICARBONATO COMPATTO SPESS. 4 mm.

DESCRIZIONE **PENS. TUNNEL PUNTONE S 60-150** GUARNIZIONI EPDM
 DISEGNATO APPROVATO

REV.	DESCRIZIONE REVISIONE	DATA
06	----	----
05	----	----
04	----	----
03	----	----
02	----	----
01	----	----
00	PRIMA EMISSIONE DEL DISEGNO	24/04/12

